

AquaSeal^{POWERGEN} : Optimize your turbine efficiency with the Dekker condenser-exhauster system.

- Efficient two-stage design provides excellent performance and condensing capabilities at high vacuum.
- Heavy duty pump design requires a minimum of maintenance.
- Features stainless steel impellers and shaft as standard.
- Features mechanical shaft seals as standard (minimizes air-leakage and shaft damage).
- Complete package design includes all necessary components for automatic operation.
- Stainless steel plate type heat exchanger offers superior heat transfer and is expandable for customized conditions, shell and tube available upon request.
- Superior evacuation (hogging) characteristics versus steam ejectors.
- Electrical control panel, including skid wiring available as an option.
- Heavy duty TEFC motors with service factor are standard.

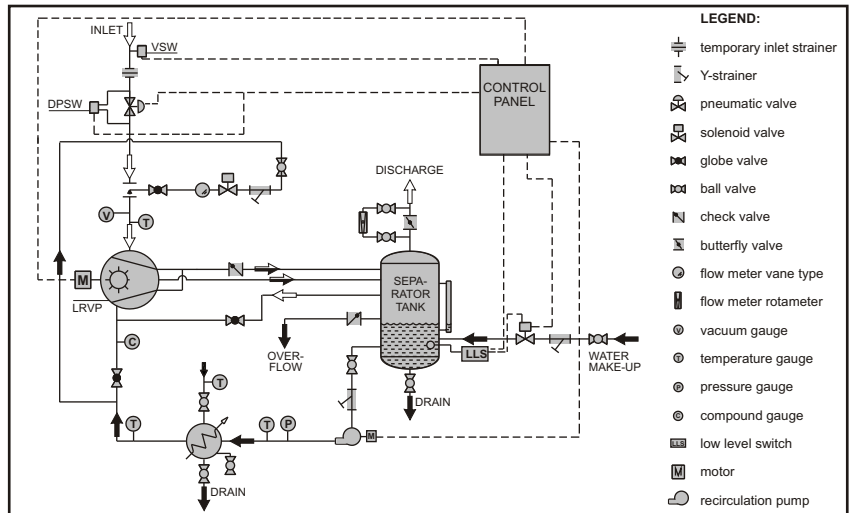

Performance Characteristics

Holding capacity*: 16 SCFM at 1" HgA
 Pump speed: 720 RPM
 Motor: 100 HP
 Weight: consult factory
 Maximum noise level (at 3 feet): 85dBA

*** Note:**

Based on 55°F cooling water to heat exchanger.
 For higher cooling water temperature see performance curve page.

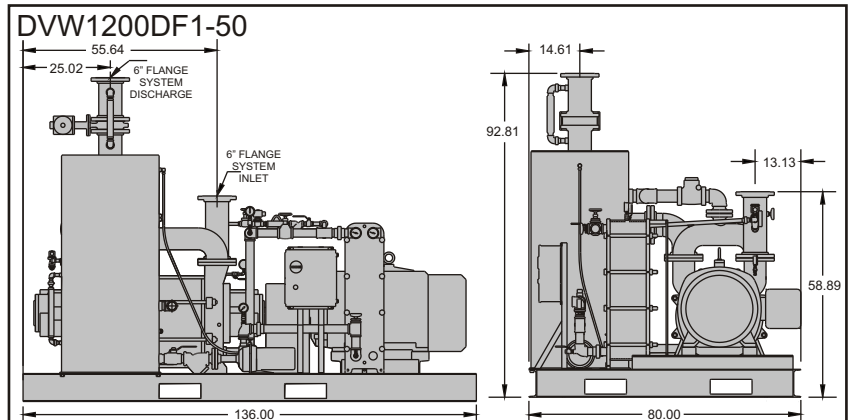

Information contained in this document is for reference only. Subject to change without notice.

DVW1200DF1-50

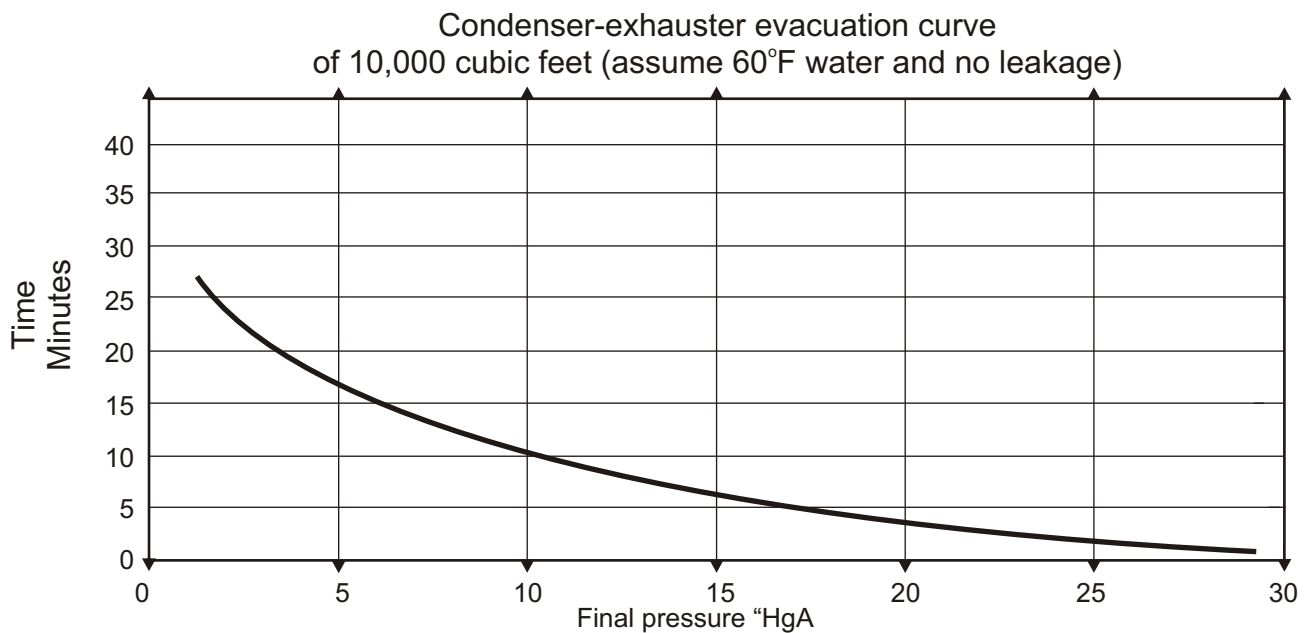
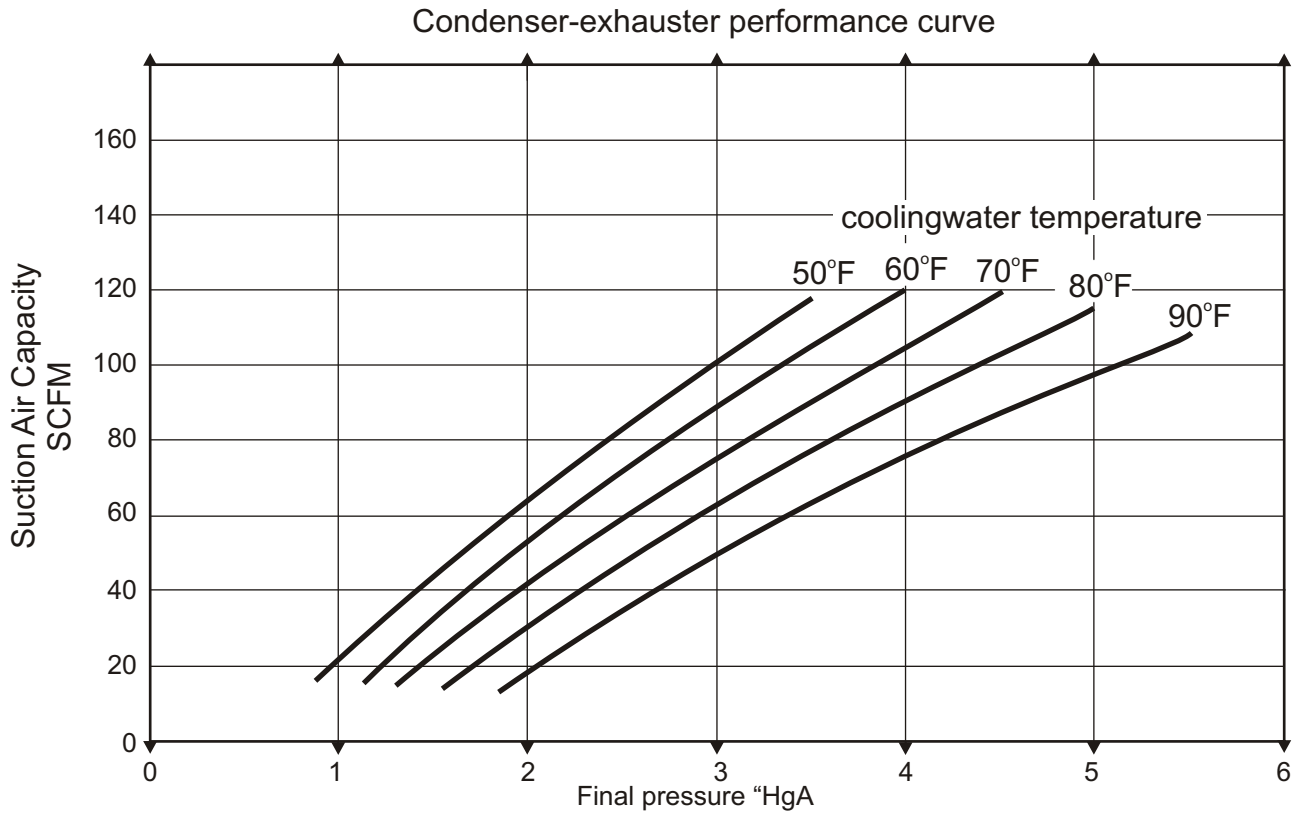

Barometric Pressure 29.92"Hg

Tolerance 10 %